

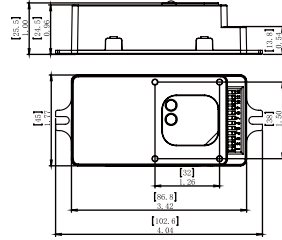

BRI810-C-F



RC-100 (OPTIONAL)



SPECIFICATIONS

Power supply	120/277VAC	50/60Hz
Maximum load @ -40°F ~ +158°F (-40°C ~ +70°C)	Resistive/Tungsten - 600W@120V Electronic Ballast (LED) - 800VA@120V/1200VA@277V	
HF System	5.8GHz CW	
Dim control output	0-10V, max. 25mA sinking current	
Detection radius/angle	Max 26ft.(8m) /360°	
Mounting height	Max 40ft	
Humidity	Max. 95% RH	
Temperature	-40°F ~ +158°F (-40°C ~ +70°C)	

NOTE: The high-frequency output of this sensor is <0.2mW that is just one 5000th of the transmission power of a mobile phone or the output of a microwave oven.

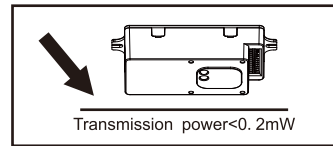

SENSOR COVERAGE

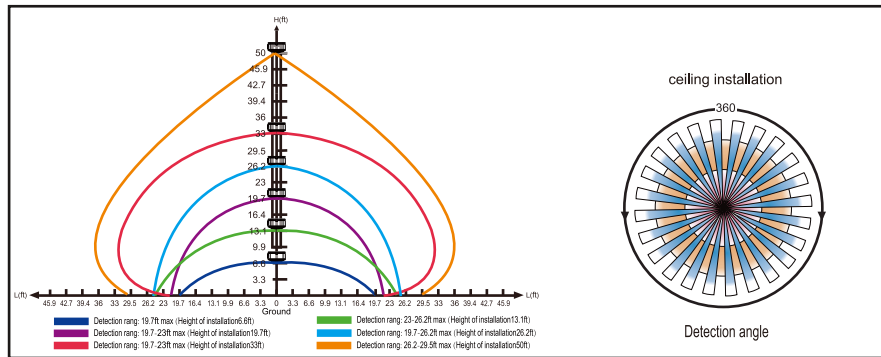

WARNING

- NOTE:** Warm up time is 15seconds. After the sensor connects input power, the light will keep on 15seconds, then go to dimming to work normally.
- NOTE:** Factory Default Setting: 100% sensitivity, Hold on time: 10seconds, Daylight sensor is 30lux, Dimming level:30%, Dimming time: 60minutes.
- NOTE:** Any setting changed by DIP Switch or remote control, the light that sensor connect will on/off as confirm.

UTILIZING FIELD AND INTRODUCTION

BRI810-C-F is a moving object sensor that can detect range of 360° and its working frequency is 5.8GHz. The advantage of this product is stable working state (stable working temperature: -40°C~+70°C), BRI810-C-F adopts a microwave sensor (high-frequency output <0.2mW), so that it is safe and performs better than infrared sensor.

FUNCTION AND OPTIONS

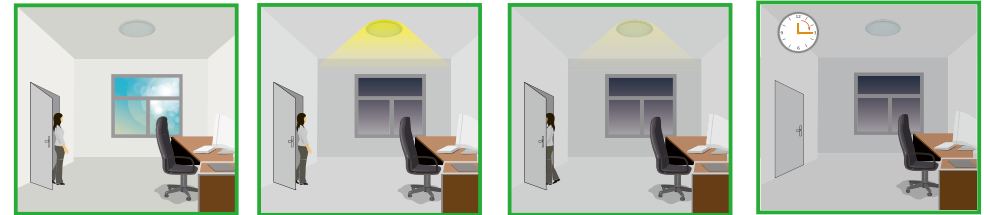

With sufficient natural light, the light does not switch on when presence detected.
 With insufficient natural light, the sensor switches on the light automatically when person enters room.
 People left, light still dims to 0/10%/30%/50% (options) standby level after the hold time.
 Light switches off automatically after after stand-by time elapsed.

WIRING DIAGRAMS

Wiring with dimming ballast or LED driver.

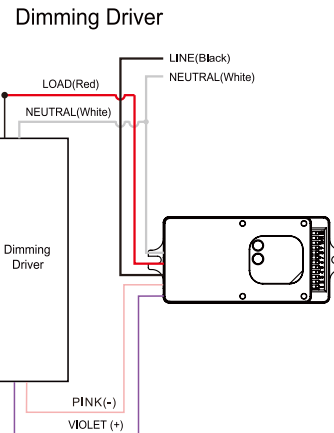

Wiring with non-dimming ballast or LED driver.

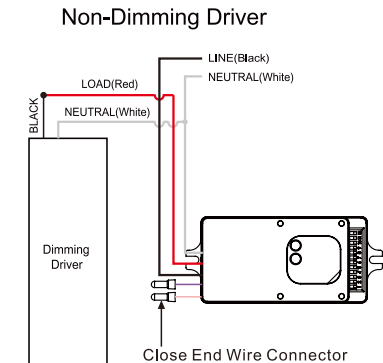

PARAMETER SETTING BY DIP SWITCH

Consider the picture: 1, 2 set sensitivity; 3, 4,5 set hold time; 6, 7,8 set stand-by time; 1, 2 set the light-control ; 3, 4 set stand-by light level ;

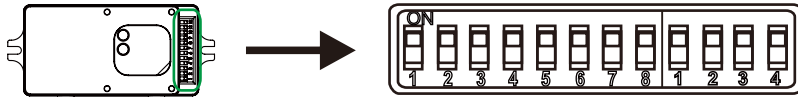

Detection Range Setting (sensitivity)

Detection rang can be reduced by selecting the combination on the DIP switches to fit precisely each application:

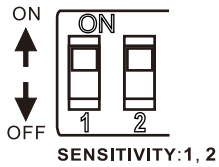

SENSITIVITY

1	2	
↓	↓	20%
↓	↑	50%
↑	↓	75%
↑	↑	100%

Hold Time Setting

The lamp can be set to stay ON for any period of time between approx.10sec and a maximum of 30min. Any movement detected before this time elapse will re-start the timer. It is recommended to select the shortest time for adjusting the detection zone and for performing the walk test. Switch location and hold time of the corresponding table is as follows:

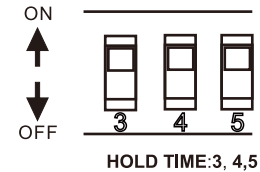

HOLD TIME

3	4	5	
↓	↓	↓	10S
↓	↓	↑	1Min
↑	↓	↑	5Min
↑	↓	↓	15Min
↑	↑	↓	30Min

Stand-by Time Setting

File of switch location and stand-by time setting as follow:

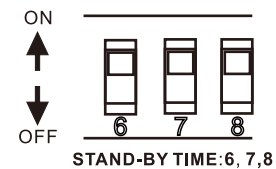

STAND-BY TIME

6	7	8	
↓	↓	↓	+∞
↓	↓	↑	1Min
↓	↑	↓	5Min
↑	↓	↓	15Min
↑	↑	↑	60Min

Light-control Setting

The chosen lamp response threshold can be infinitely from approx. 10-50lux, switch location and light-control of the corresponding table is as follows:

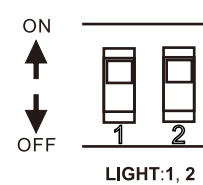

LIGHT

1	2	
↓	↓	☀ (light sensor disable)
↓	↑	10Lux
↑	↓	30Lux
↑	↑	50Lux

Stand-by Light Level Setting

The corresponding file of switch location and stand-by level as follows:

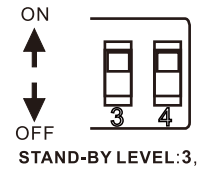

STAND-BY LEVEL

3	4	
↓	↓	0%
↓	↑	10%
↑	↓	30%
↑	↑	50%

PARAMETER SETTING BY REMOTE CONTROL IN MANUAL OF RC-100.