

Hourglass Post Top Light



Black finish

MODEL #	
PROJECT:	
NOTES:	
DATE:	
PREPARED BY:	

PRODUCT FEATURES:

- ❖ Optical design, greatly improved the light utilization and evenness.
- ❖ High efficiency LED Driver.
- ❖ Cast Aluminum design, better cooling, light quality, LED Tj < 85°C.
- ❖ Excellent efficacy ≥ 135lm/w.
- ❖ 1-10V Dimming.

Additional Information:

- Power: 100W
- Input: AC 120-277V
- CCT : 4000K/5000K
- Light Source: SMD 2835 LEDs
- Driver: KERHAM POWER



PRODUCT APPLICATIONS:

The Hourglass Post Top Light LED Lighting Series can be widely used for Outdoor (Wet Location) Excellent for Lawns, Courtyards, Roadways and many other applications.

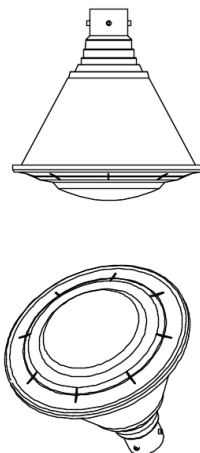
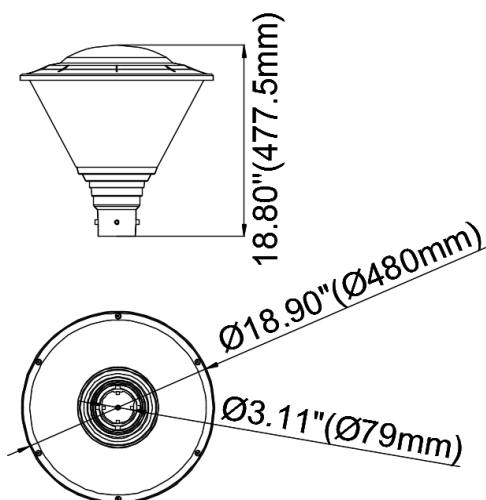

Structure Features:

- Shell Materials: Aluminum & PC
- Finish: Dark Bronze/White/black/Silvery(OPTION)
- Net Weight: 6.46KG (14.2 LBS)
- **Product Size: 480mmX477.5mm**
18.9"x18.8"
- **Carton Size: 485mmX485mmX480mm**
19.09"x19.09"x18.9"

Hourglass Post Top Light

TECHNICAL PARAMETERS:

Type	SB-HPT10W27-XXK-Z-E		
Power	100W	Lighting Angle	159°
Input Voltage	AC120-277V	LED Brightness Decay	<5%/6000 hrs
PF	≥0.90	Working Life	>75000 hrs
Driver Efficiency	≥87%	Working Temperature	-30 - +45°C
Luminous Flux	13210 Lm	Storage Temperature	-40 -+80°C
Color Temperature	4000K/5000K	Protection Level	Wet Location
CRI	Ra>70	Cable	3core,18AWG (19.69 inch)

PHOTOMETRY:

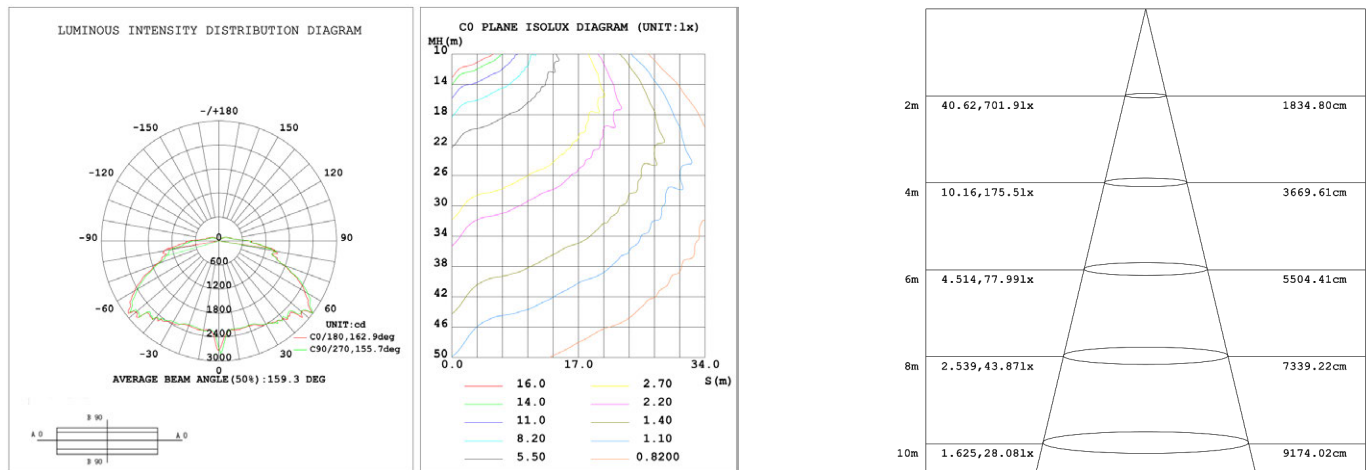

ORDERING EXAMPLE: SB-HPTG210W27-XXK-Z [D, W, B, S] -E [blank,M]

SB	HPT	10W	27	XXK	Z	E
Company	Product	Power	Voltage	ColorTemp	FINISH	Control
SNOWBALL	HPT Hourglass Post Top Light	10 W (100W)	AC120-277V	40K (4000K) 50K (5000K) standard ± 500K	D (Dark Bronze) W (White) B (Black)standard S (Silvery)	M Motion Sensor