



PLEASE READ ALL INSTRUCTIONS BEFORE ATTEMPTING INSTALLATION

- To prevent personal injury or product damage only licensed electricians should install.
- To avoid electric shock or component damage disconnect power before attempting installation or servicing.
- This product must be installed in accordance with the national electric code (NEC) and all applicable federal, state and local electric codes and safety standards.
- Disconnect product and allow cooling prior to servicing.
- Any alteration or modification of this product is expressly forbidden as it may cause serious personal injury, death, property damage and/or product malfunction.
- To prevent product malfunction and/or electrical shock this product must be properly grounded.
- This luminaire is designed to operate in ambient temperatures ranging from -30°C to 40°C and to be horizontally mounted with the LEDs facing down.
- Wall Pack only.

1. Unpacking

Thoroughly inspect the fixture for freight damage. Freight damage should be reported to the delivery carrier.

2. Installation

- 1) .Twist lock PC cover as shown and reflectors screws removed after the PC cover and reflector.

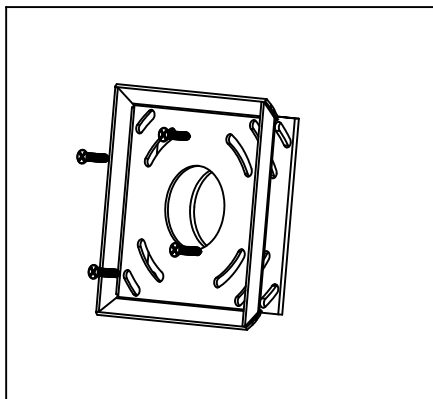

- 2) .Use electric drill and radiator photogenic corresponding mounting holes on the wall, and labeled waterproof foam rubber and tighten the screw.

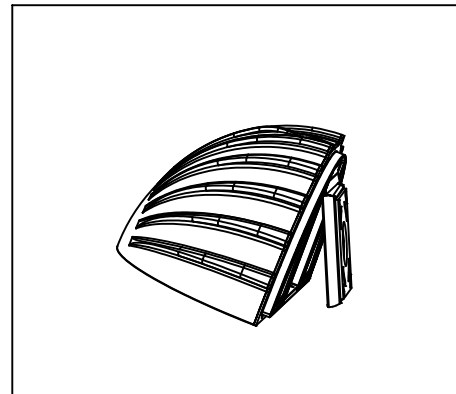

- 3) .Tighten the radiator screw then connect a good AC line and grounding line.

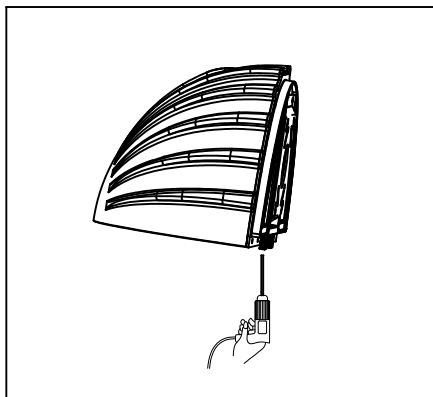

- 4) .After connected line, fitted with a reflector and PC cover, screw down the screws.

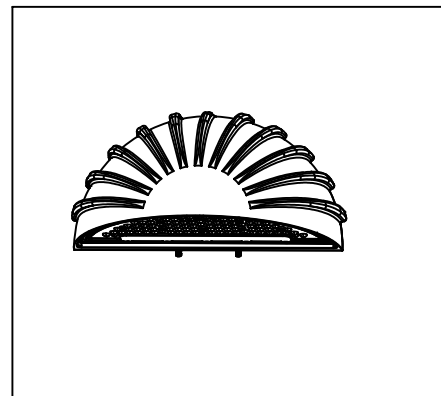

3. Checking

- 1). Does all the wires connect in a correct way as the pictures show below?
- 2). Is the ground lead installed appropriately?
- 3). make sure the photocell function well.