

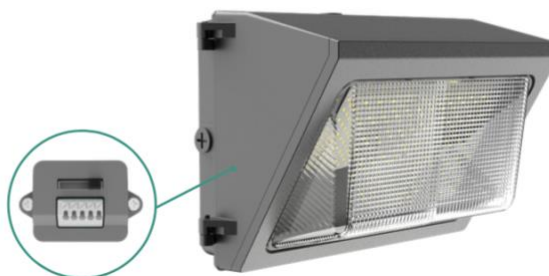

DESCRIPTION

The SB-WP01 Adjustable LED Wall Pack light with die Cast aluminum alloy heat sink, is one of the most dependable lights for security lighting luminaire. It is designed for areas like outdoor lighting and courtyard illumination.

DIP Switch - 3 CCT & 4 Wattages Selectable



SB-WP01-100W-CCT LED Classic Wall Pack
CCT: 3K/4K/5K Power: 100W/75W/50W/25W Selectable



Integrated Photocell Sensor available



OVERVIEW:

- Efficiency: Up to 125 LPW
- Delivered Lumens: Up To 12,500 lumens
- Power Selectable: 100W/75W/50W/25W
- Color selectable: 3000K/4000K/5000K
- Power factor > 0.9
- ETL Wet Location Listed, IP65

- CRI: >70
- Input Voltage: 120-277V
- Limited Warranty: 5 Years, 50,000-hour at 25°C
- 0-10V dimming, Photocell EM available
- Operating temperature: -30°C to +45°C, -22°F to 113°F
- Surge Protection, L-N:2KV L/N-PE:4KV

SPECIFICATION FEATURES

Construction

Constructed of high grade, heavy-duty IK08 High-Duty die cast aluminum. Wet location, IP65 rating achieved utilizing outdoor rated. Lens Material, glass.

Thermal Management

The WP01 series provides excellent thermal management using the aluminum housing as a heat sink, drawing heat away from critical components. This enables the Luminaries to withstand higher ambient temperatures without degrading LED life.

Electrical

0-10V dimmable 120- 277V, 50/60Hz, , photocell and Emergency battery back up available, CCT Selectable and wattage Switchable, Surge Protection, L-N:2KV L/N-PE:4KV

Compliance

ETL listed for Wet location

Finish

Finish is powder-coated to promote maximum protection against fade and wear. All finishes are available in standard Dark Bronze and custom colors are available.

Warranty

5-year limited warranty.

Optics

Glass lens.

DIMENSION

SB-WP01-100W-CCT

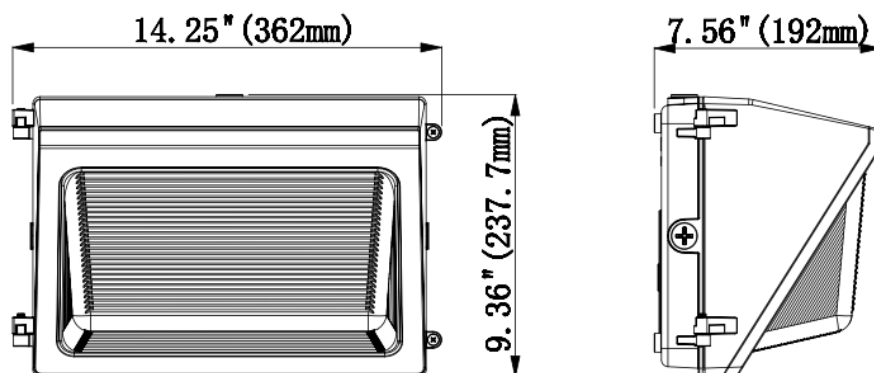

CONTROLS:**120-277VAC PHOTOCONTROL**

Universal Voltage photo controls. Dusk-to-dawn
4W/8W Emergency battery back available

*** MODEL SELECTION:****Example: SB-WP01-100W-CCT**

Products series	Wattage	Kelvin	Voltage	Finish	Options
SB-WP01	*100W=100W/75W/50W/25W Selectable	*CCT=3000K/4000K/5000K Selectable	*Blank=120-277v	*Blank=Dark Bronze	Blank=0-10V dimming
				B = Black	
				W = White	
				S = Silver	

ACCESSORY

Item Accessory	MODEL NUMBER	DESCRIPTION
Options	SB-PF	Field install Dusk to Dawn Photocell Switch 120-277V // JL-413C
	SB-PF-B	Factory install Dusk to Dawn Photocell Switch 120-277V // JL-413C
	SB-EBP-4W	Emergency battery back up 4W 90 minutes
	SB-EBP-8W	Emergency battery back up 8W 90 minutes

GENERAL PERFORMANCE

Wattage±10%	KEVIN±10%	DELIVERED LUMEN±10%
25W	3000K-5000K	3125
50W	3000K-5000K	6250
75W	3000K-5000K	9375
100W	3000K-5000K	12500